

ARBOR PRESSES
SERIES 422:

- Heavy duty construction
- Precision made
- 4-way anvil

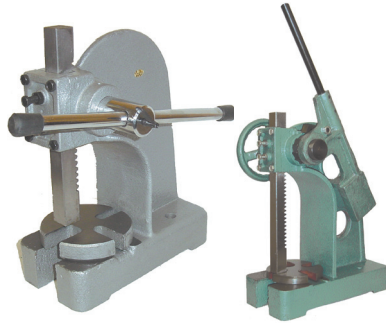

MEGA
Superior Import

Ratcheting
Type

PANAPRESS
SERIES 345:

PANAVISE
Made In U.S.A.

Model 502

Ideal for pressing bearings, sleeves, collars, forming and assembling small parts, broaching, staking, etc.

- Reversible ram is 0.75" x 0.75" (19.1mm x 19.1mm) and 5.875" (149.2mm) long and applies up to 1/4 ton (500 lbs/227 kg) of pressure!
- One end of the ram is pre-drilled for adding tooling
- Four adjustable nylon gibs provide exceptional ram control
- Arm is 8" (203.2mm) long.
- Base footprint is 3.7" (94 mm) x 7" (177.8mm) and includes four 0.25" (6.3mm) holes countersunk at the corners for bolting to a work surface.
- Height (from base to top of back-not including variable ram height or arm length): 7" (177.8mm).
Weight: 5.4 lbs. (2.5 Kg).

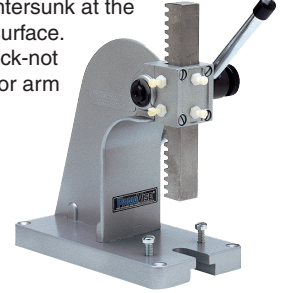

Order No. 3450502
Price **\$175.99**

Model No.	Tons Pressure	Height Over Table	Height of Press	Base Size	Leverage Ratio	Wt.	Order No.	Price
0	1/2	4-1/2	10	4 x 9-1/2	20:1	25 lbs.	2405000	\$39.50
1	1	5-1/2	13	5 x 11	25:1	40 lbs.	2405001	\$59.75
2	2	8-1/2	18	6-3/4 x 17	35:1	88 lbs.	2405002	\$123.50
3	3	12-1/2	23	8 x 18	50:1	160 lbs.	2405003	\$180.50
5	5	18	35	10 x 26-3/4	50:1	325 lbs.	2405005	\$707.00
Ratcheting Type - For Heavier Applications								
2R	2	8-1/2	18-1/2	6-1/4x15-3/4	-	99 lbs.	2401222	\$185.00
3R	3	12-5/8	21-1/2	8 x 18	-	178 lbs.	2401013	\$315.65
5R	5	18-1/4	34-1/2	11.5 x 26.5	-	380 lbs.	2401015	\$802.50

PHASE-A-MATIC PHASE CONVERTERS
SERIES 222:

Runs three-phase equipment on existing 220V single-phase power

For long heavy starting loads, instant reversing, momentarily overloaded motors, or imported equipment; please inquire. Voltage stabilizer available for high line voltage and voltage-sensitive equipment such as CNC's; please inquire.



STATIC CONVERTERS
(Runs motor loads only at 2/3 rated HP)

How to Size:

The largest motor on your machine must fall within the minimum and maximum range of the converter. Do not order a larger unit or heavy duty model thinking it will give you more horsepower.

When To Use Heavy Duty:

Heavy starting loads (lathes, flywheel driven equip., etc.). Instant reversing, frequent starting, jogging. Air compressors (motor pulley must be reduced by 1/3 diameter).

Heavily Loaded Equipment:

Pumps, fans, blowers, direct-drive compressors, or equipment requiring greater than 2/3 of its rated HP, use a **PHASE-A-MATIC** rotary converter listed below.



For Light to Moderate Loads

Regular Duty Series			
Model No.	Order No.	H.P. Range	Price
PAM-100	2220100	1/3 TO 3/4	\$99.00
PAM-200	2220200	3/4 TO 1-1/2	\$111.00
PAM-300	2220300	1 TO 3	\$123.00
PAM-600	2220600	3 TO 5	\$144.00
PAM-900	2220900	4 TO 8	\$177.00
Heavy Duty Series			
PAM-100HD	2221100	1/3 TO 3/4	\$132.00
PAM-200HD	2221200	3/4 TO 1-1/2	\$147.00
PAM-300HD	2221300	1 TO 3	\$165.00
PAM-600HD	2221600	3 TO 5	\$198.00
PAM-900HD	2221900	4 TO 8	\$240.00
PAM-1200HD	2211200	8 TO 12	\$333.00
PAM-1800HD	2211800	12 TO 18	\$615.00
PAM-3600HD	2213600	20 TO 30	\$837.00
PAM-5000HD	2215000	30 TO 50	\$1257.00

ROTARY CONVERTERS
(For running motor loads greater than 2/3 rated HP)

FEATURES:

- Multi-motor operation
- Multi-speed applications
- Resistive load applications
- No changing motors or switch gear
- Full 12 month warranty
- Easy to install
- No interference to TV, etc.

For larger sizes or 460V operation, please inquire.



Heavy Load Applications

Model No.	Order No.	H.P. Range	Price
R-1	2222001	1	\$432.00
R-2	2222002	2	\$524.00
R-3	2222003	3	\$628.00
R-5	2222005	5	\$820.00
R-7	2222007	7-1/2	\$1076.00
R-10	2222010	10	\$1396.00
R-15	2222015	15	\$1956.00
R-20	2222020	20	\$2368.00
R-30	2222030	30	\$3232.00
R-40	2222040	40	\$4028.00
R-50	2222050	50	\$4760.00
R-60*	2222060	60	\$6460.00
R-80*	2222080	80	\$8056.00
R-100*	2222100	100	\$9520.00

*Multiple Unit Model

QUILL STOP

SERIES 508:



- Quick acting clip easily attaches to quill of Bridgeport® or similar type machines for rapid depth setting
- Top or bottom positioning
- Easily removable

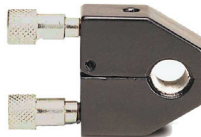

Order No. 2585003	Price	
-------------------	-------	--

QUILL FEED HANDLE

SERIES 508:



Replaces conventional handle for speeding up operations on Bridgeport® type machines.



Order No. 2585001	Price	
-------------------	-------	--

HAND SHEAR MACHINES

SERIES 508:



- Lever type
- Ideal machine for shearing sheet, steel, bars and rods.
- Hardened and tempered replaceable blades.
- Long handles provides plenty of shearing torque.
- Comes with predrilled holes to bolt down to work bench.



Order No.	Blade Length	Weight	Price
5086001	6"/150mm	26lbs/12kg	
5086002	8"/200mm	40lbs/19kg	
5086003	10"/250mm	48lbs/22kg	
5086004	12"/300mm	54lbs/24kg	

TWO-LIFE DRAWBARS

SERIES 508:

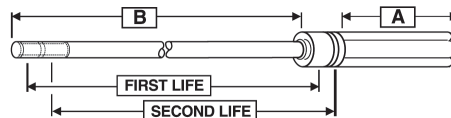

- Two drawbars in one
- Prevents excessive downtime
- Longer hex head & extended thread length
- To obtain "second life" after the end wears out, cut off at "V" notch and remove large spacer

Order No.	Dim. "A"	Dim. "B"	Thread Size	Type of Milling Mach.	Price
5081026	4-1/4	18-1/4	R8 7/16-20	Variable Speed	
5081028	1-1/2	18-1/4	R8 7/16-20	Step Pulley	

CLOCK SPRING ASSEMBLY

FOR MOST BRIDGEPORT® TYPE MACHINES



SERIES 508:



Order No. 5081112	Price	
-------------------	-------	--



MACHINE MOUNTS

SERIES 450:



Effectively Isolate Vibration In Two Ways:

1. By preventing a vibrating machine from transferring vibration to other machines.
2. By insulating precision machinery from external sources of vibration.

Choosing the Correct Royal Machine Mounts. Calculate the load on each mount by dividing the total weight of the machine by the number of mounting locations. Note: sometimes it may be necessary to compensate for machines which do not have an evenly distributed load.

Type	1	2	3	4	5
Order No.	27001	27002	27003	27004	27005
Load Range per Mount (lbs.) General Non-Impact Machinery	100-1,100	880-2,200	1,760-5,500	3,300-8,800	6,600-12,000
Load Range per Mount (lbs.) Presses					
125 strokes/min-max	150-440	440-880	880-3,080	3080-5,940	5,940-8,800
180 strokes/min-max	130-300	260-770	770-2,420	2420-4,290	4,290-7,700
200 strokes/min-max	110-260	260-550	550-1,760	1760-2,860	2,860-5,280
Max. Load per Mount (lbs.) Plastic Injection Molding Machines	390	790	2,180	5,450	8,220
Diameter	3-5/32"	4-3/4"	6-5/16"	6-5/16"	7-7/8"
Height, Including Leveling Plate	1-5/8"	1-15/16"	2-5/16"	2-5/16"	2-23/32"
Over-All Height	5-1/4"	5-1/4"	7-1/2"	7-1/2"	7-7/8"
Level Adjustment	23/32"	23/32"	1"	1"	1"
Leveling Bolt Size	M12x1.25	M16x1.5	M20x1.5	M20x1.5	M20x1.5
Standard Leveling Bolt Length	4-23/32"	4-23/32"	6-11/16"	6-11/16"	6-11/16"
Price Each					

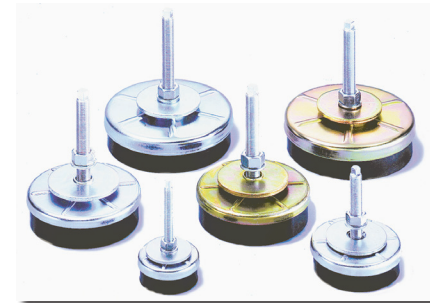

- Royal Machine Mounts meet OSHA requirements by preventing machines from "walking" - without the need for bolting or cementing.
- All mounts incorporate a large, chloro-prene rubber base which is resistant to oil, water, and many chemicals.
- All metal parts are zinc plated for rust protection and long life.
- Support cup is machined from a solid bar instead of deep drawn, resulting in increased thickness and longer life.
- Unique retaining clip ensures that mounts will stay together when machine is moved to a new location.
- Better machine performance and reduced maintenance costs are two of the many benefits of using Royal Machine Mounts.

Stainless steel and zinc plated mounts available; please inquire.

POWER FEED
SERIES 508:



LONGITUDINAL

- New stronger design with polished aluminum housing.
- 110v with manual reset switch.
- Eliminate gear changing.
- Auto cut-off at end of cut.
- Pilot light.

"X" and "Z" Axis Power feeds available; please inquire.

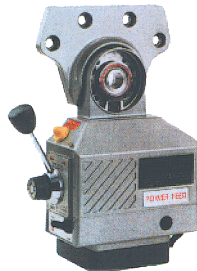

SPECIFICATIONS:

Speed Range: 1-9" per minute
Rapid Traverse: 40" per minute
Torque Rating: 135 lbs/in
Gearing: Helical

Order No. 5080015	Price	
-------------------	-------	--

ELECTRONIC COUNTER & ELECTRONIC TIME COUNTER
SERIES 257:



- Super compact, large LCD display, long battery life, panel mount, reset.
- Connection: Lead wires, wire-wrap terminals.
- Counter has 30 cycle per second counting speed. Counts to 99,999,999.
- Time counter - elapsed time up to 99,999.99 hours.

Electronic Counter

Order No. 2575000	Price	
-------------------	-------	--



Electronic Time Counter

Order No. 2577500	Price	
-------------------	-------	--

DIGITAL READOUT KITS

SERIES 725:

Digital Z-Axis Readout for Bridgeport® Type Mills



Horizontal



- Can be mounted on almost any surface.
- SPC Output • Resolution .0005" / 0.01mm.
- Accuracy: ± .001" / 0.03mm
- LCD unit displays "E-05" for movement error.
- Includes 2 mounting brackets and EZ mount bracket kit.
- Offers precise linear measurement capabilities.
- One SR44 1.5V battery is supplied.
- Sliding unit can be moved 40" per second.

Range	LCD Horizontal		LCD Vertical	
	Order No.	Price	Order No.	Price
6"/150mm	7250061		7250062	
8"/200mm	7250081		7250082	
12"/300mm	7250121		8250122	
18"/450mm	7250181		8250182	

PRO/CALC® - MATERIAL DIRECTORY & SPINDLE SPEED CALCULATOR
SERIES 508:



Throw out those oil stained charts!

Pro/Calc® takes the guess work out of the question "what RPM should I be using?"

The Pro/Calc® a hand held battery operated reference directory that requires no mathematical computation

It is as easy as 1-2-3

Simply Select:

- 1- Material to be machined (80% of the most used metals)
- 2- Operation: cut-off, form tool, end mills, counterbore, turning, fly-cutting, face milling, tapping, reaming, and drilling.
- 3- Diameter of tool.

The correct RPM will automatically be displayed. (Also displayed are heat treated materials and tap drill sizes.)

Order No. 6000008	Price	
-------------------	-------	--



BLUE KNEE LENGTH APRON
SERIES 309:



39" overall; knee length with full bib and pocket.

Order No. 1915500	
Price	



5-FIGURE DIGIT COUNTER
SERIES 257:



Counts to 99,999. Reset knob for quick "zero" setting. 4 holes in base for easy and rigid mounting. Counter is activated by a 45° movement of the arm. Unit comes with a spring on the lever arm for attaching to machine.

Order No. 1735005	Price	
-------------------	-------	--



QUILL KIT
SERIES 572:

Easy Installation Fits Most Vertical Knee Mills

FEATURES:

- Easy to read LCD with resolution of .0005"/0.01mm
- Push button controls for inch/mm, Zero-Set and On/Off
- Powered by a single SR-44 Battery which lasts about 1 year with normal use
- SPC Output for data transmission to Data Processors or LED Remote Display Box



Kit mounted on a vertical mill

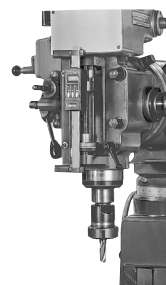

Digimatic Quill Kit complete with brackets & scale for Bridgeport® Type machines.

Order No. 053-906	
Price	

**NEW MITUTOYO AOS - DRO SYSTEM
KA COUNTER WITH AT - 715 MAGNETIC SCALES**

SERIES:

KA Counter

- Selectable Resolutions (.00005, .0001, .0002, .0005”) allows choice according to the tolerance requirements of the work being performed
- Bolt Circle Calculation (eliminates need to use trigonometry to calculate hole positions)
- Diameter Mode (doubles reading on cross axis of lathe)
- Tool Offsets (stores datum points for 10 tools which eliminates need to re-zero after tool changes)
- Connectable with AT-715 Magnetic scales or AT-100 series Glass scales (allows use of magnetic and/or glass scales for different applications)
- RS-232 Output (optional) allows data capture and storage on remote computer
- Touch Probe (optional) allows automatic edge detection for zeroing part



AT-715 Magnetic Scales



- Fully submersible in coolant (coolant never effects scale position reading)
- +/- .00012” accuracy over ft./12 in.
- True Absolute (no battery backup - means position information is never lost, even after power interruption)
- Shock Resistant
- Reader Head mounted on saddle guide for easy installation (alignment not as critical)

**ABS AOS DRO Linear Scale System
SPECIFICATIONS**

AT715 Linear scale

Detection system	Electromagnetic induction system (3 tracks, absolute AOS)	
Resolution	0.005 mm / 0.002 mm / 0.001 mm (Changeable by parameter setting) .0005 inch / .0002 inch / .0001 inch / .00005 inch (Changeable by parameter setting)	
Dimensions	Height	1.43" / 36.5mm
	Width	.87" / 22mm
	Length	varies according to travel length specified/ordered
Effective range	3.94" x 70.87"/100 ~ 1800 mm	
Signal output	Mitutoyo original Serial format (can not connect to KL, KLL, KS, KC Counter)	
Accuracy	(7 + 13L / 1000)um [L : Effective range (mm)]	
Maximum response speed	50 m / min.	
CE marking	Corresponding to the regulations	

KA-Counter

Resolution	0.005 mm / 0.002 mm / 0.001 mm (Changeable by parameter setting) .0005 inch / .0002 inch / .0001 inch / .00005 inch (Changeable by parameter setting)
Readout	2-axis, 3-axis (Using 2-axis counter for 1-axis requirement.) (For lathes, using 3-axis counter with the parameter setting changed
Display	Seven segment LED / 7 digit, 1 digit for coordinate number
Main function	Zero setting, Preset, Low digit OFF, 10 coordinate position memory, Bolt-Hole-Circle, mm / inch conversion, Counting direction setting, Resolution setting (Parameter setting), Diameter display, 1/2 calculation, Smoothing display, Tool offsets (Parameter setting)
Input	Automatic discrimination of scale connected ABS AOS DRO scale (AT715 and AT100 series) 2Vpp sine wave
Output	RS-232C interface (Option)
CE marking	Corresponding to the regulations



DIGITAL READOUT SYSTEMS



SERIES 572:

**MAGNETIC ABS - AOS - DRO
PACKAGE FOR MILLING SYSTEM**

USING KA COUNTER AND AT715 SCALES

2 Axis, KA Counter Milling System

Specify "Package" number when ordering.

	Y Axis Travel			
	AT715-300 (12")	AT715-350 (14")	AT715-400 (16")	
	For Bridgeport #1	For Taiwan	For Lagun	For Taiwan
AT715-750 (30") Axis Travel	Package Number 174-173PM1	Package Number 174-173PM3	Package No.	Package No.
AT715-900 (36") Axis Travel	174-173PM2		174-173PM4	174-173PM5
AT715-1000 (40") Axis Travel		174-173PM6	174-173PM7	174-173PM8

Package Includes:

- KA Counter
- Brackets for Scales
- AT715 Linear Scales
- Display Arm Kit

Order No. 5720001

Price

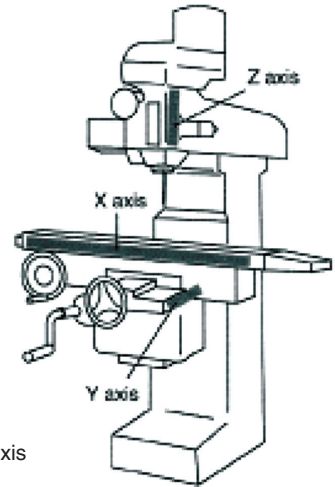

3 Axis, KA Counter Milling System (Z axis length 6")

	Y Axis Travel			
	AT715-300 (12")	AT715-350 (14")	AT715-400 (16")	
	For Bridgeport #1	For Taiwan	For Lagun	For Taiwan
AT715-750 (30") Axis Travel	Package Number 174-175PM1	Package Number 174-175PM3	Package No.	Package No.
AT715-900 (36") Axis Travel	174-175PM2		174-175PM4	174-175PM5
AT715-1000 (40") Axis Travel		174-175PM6	174-175PM7	174-175PM8

Package Includes:

- KA Counter
- Brackets for Scales
- AT715 Linear Scales/
AT715-150mm (6") for Z axis
- Display Arm Kit

Order No. 5720002

Price

AT100 SERIES - GLASS SCALE UNITS

FEATURES

1. Low-priced model AT115

The low-priced version of Mitutoyo Linear Scale AT115 series are available. The mounting dimensions of all the AT115 models are the same as those of the AT111 series. Most suitable for mounting on a milling machine or an XY table.

2. Joint structure of detector

The ball joint structure is employed at the joint of the detector head and the slider (sensor unit) inside the scale. This structure prevents the slider movement from deviating from the normal moving directions when the detector head shifts to right and left, thus providing a normal scale reading and increasing flexibility in the scale installation. In addition, this structure is highly rigid and therefore has an excellent durability.

3. Water-proof connector

A waterproof/splash-proof connector is used to enable separation of the signal cable. Thus, an installation and maintenance of the Linear Scale can be easily performed. (The signal cable in AT115 cannot be separated.)

4. Conduit armored type signal cable

A waterproof/splash-proof connector is used to enable separation of the signal cable. Thus, an installation and maintenance of the Linear Scale can be easily performed. (The signal cable in AT115 cannot be separated.)

5. Unique rubber-lip openings

The rubber-lip openings are shaped like the bottom of a ship that plows the water.

6. Excellent splash and dust-proof rubber lip structure

The rubber lips are made of a strong, special urethane and wires are inserted in these lips to improve the splash-proofing and dust-proofing of the scale. (AT102 only)

**GLASS LINEAR SCALE PACKAGE
FOR GRINDER SYSTEM**

USING KA COUNTER AND AT115

2 Axis, KA Counter Grinder System

Specify "Package" number when ordering.

Vertical	Cross Side			
	AT115-150 (6")	AT115-200 (8")	AT115-250 (10")	AT115-300 (12")
AT115-300 (12")	Package Number 174-173PG1L	Package Number 174-173PG8L	Package Number	Package Number
AT115-350 (14")	174-173PG7L	174-173PG3L	174-173PG5L	
AT115-400 (16")		174-173PG4L	174-173PG13L	
AT115-450 (18")	174-173PG2L	174-173PG9L	174-173PG6L	174-173PG14L
AT115-500 (20")	174-173PG10L	174-173PG11L	174-173PG15L	
AT115-600 (24")	174-173PG12L	174-173PG16L		

Package Includes:

- KA Counter
- AT115 Glass Linear Scale / Magnetic Scale available at same price; please inquire
- Bracket Kits
- Display Arm Kit

Order No. 5720003

Price

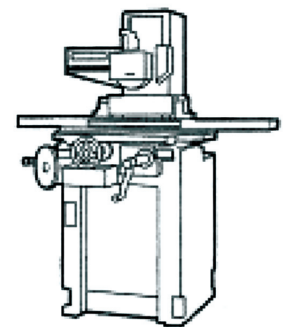

Many other packages available; please inquire.

**LINEAR SCALE PACKAGES
FOR LATHES**

Package Includes:

- KA Counter
- AT115, AT102 Glass Linear Scale and Extension Cable.
- Bracket Kits
- Counter Stand
- Counter Tray

2 Axis, KA Counter Lathe System

Z Axis Travel	X Axis Travel		
	AT115-200 (8")	AT115-250 (10")	AT115-300 (12")
AT715-1000 (40")	Package Number 174-173PL3	Package Number 174-173PL4	-
AT715-1200 (48")		174-173PL6	-
AT715-1500 (60")		174-173PL7	174-173PL29

Z-Axis Travel	Order No.	Price
1000	5720004	
1200, 1500	5720005	

Specify "Package" number when ordering.

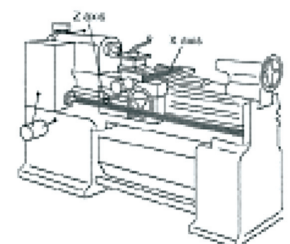



MACHINE SAFETY GUARD SYSTEMS

SERIES 986:



SAFETY PRODUCTS

VISORGUARD™

Unbreakable Lexan® Shield Provides Complete Protection Between Cutting Tool and Operator's Eyes.

DOWN-TO-EARTH-FEATURES!

- Flexbar® arm permits setting of Visorguard™ at the correct height and angle for each setup.
- Flip shield up to load part and down for machining.
- Special spring-loaded shaft makes shield stay put - no springback.
- Wing-shaped shield protects workers at adjacent machines.
- Flexbar® locks rigid; has stainless aircraft grade tension cable.
- Can be installed in minutes on CNC mills, conventional milling machines and others.



Dimensions:

- Shield Size - 16" wide X 8" high
- Flexbar arm - 10" long

Model No.	Description	Order No.	Price
13055	Visorguard™ Complete with Mounting Bracket, Flexbar, and all mounting hardware.	8613055	
13050	Long Reach Visorguard™ Up to 40" total reach. Complete with hardware, tube and mounting bracket.	8613050	
13054	Lexan® Shield Replacement for both guards.	8613054	

While we show only the popular **FLEXBAR** items we can supply their entire range of products; please inquire.

LATHEGUARD™

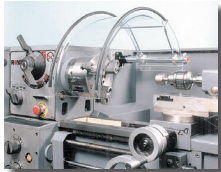

- Ready to mount: affix mounting bracket with two screws.
- Back of shield reinforced with plated wire-form housing.
- Locks in swing away or functional positions.
- Swings away easily
- Heavy Duty Cast Mounting bracket supplied.
- Heavy Duty Chrome-plated extension tube and hardware.

- Clear Lexan®, semi-circular Wrap-a-round Guards.
- Rib reinforced
- Robust construction
- Light in weight

EXCEEDS O.S.H.A. REQUIREMENTS

Model No.	Suggested Lathe Size	Center Height	Use With Chucks	Shield Width	Shield Length	Tube Length	Order No.	Price
12999	Very Small Lathes	3.9"	up to 6" dia.	6-1/4"	7.8"	10"	8612999	
13060	6" to 12"	6"	up to 8" dia.	6-1/4"	11.8"	10"	8613060	
13061	12" to 16"	8"	up to 12" dia.	8"	15.8"	11-1/2"	8613061	
13062	16" to 20"	10"	up to 16" dia.	8"	19.70"	13"	8613062	
13064	20" to 24"	13"	up to 20" dia.	8"	23.6"	13"	8613064	

TRAVELGUARD™

Cross slide type.

Extra-heavy duty O.E.M. type for Lathes, Grinding Machines, etc.
Travels with cross slide operator protection wherever tool is cutting.

- Easy to mount on cross slide (tool compound).
- Fully adjustable in all directions- forwards & frontwards.
- Heavy steel construction with thick Lexan® window.
- Frame is 3/4" construction made of heavy gauge steel with high quality painted finish.
- Front panel is hinged and can be lifted for quick access to machine.

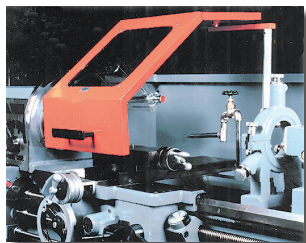

Model No.	Description	Order No.	Price
13086	20" Chuck Max	8613086	
13087	28" Chuck Max	8613087	

THE LEXAN® FLEX-SHIELD

Protects Your Eyes Against Chip & Liquid Burns. Safety Shield on Flexbar® Universal Positioning Arm. Quick Cam Action Locking (Shield swivels 360° and locks positively where placed).

- Overall Height of Flexbar Stand: 14"
- Super Power Disc Mag Base: 3.16" dia.
- Shields made of durable clear view Lexan - 1/8" thick.
- Choice of concave or flat.

Concave Shield Models - Complete

Model No.	Shield Size	Order No.	Price
13313	6" x 8"	8613313	
13314	8" x 10"	8613314	
13315	10" x 12"	8613315	



Flat Shield Models - Complete

Model No.	Shield Size	Order No.	Price
13316	6" x 8"	8613316	
13317	8" x 10"	8613317	
13318	10" x 12"	8613318	

Lexan® Replacement Shields - Carton of 3

Shield Size	Concave			Flat		
	Model No.	Order No.	Price	Model No.	Order No.	Price
6" x 8"	13093-L	8613093		13120-L	8613120	
8" x 10"	13094-L	8613094		13121-L	8613121	
10" x 12"	13095-L	8613095		13122-L	8613122	

PANEL GUARD™

Portable, yet sturdy free-standing guard. Ideal for separating or back guarding machines. Additional panels can be added to cover any size area.

Flexbar Panel Guards™ consist of 4 hinged panels with a pivot spine. Frames are extruded aluminum; inserts are replaceable; lower panels are safety colored, tempered masonite; upper panels are 1/8" thick, high impact resistant, transparent Lexan® Panel Guard™ does not obstruct air circulation or visibility, yet confines chips and oil to machine area for easy cleanup.



Model No.	Description	Order No.	Price
13035	Flexbar Panel Guard™ Basic 4-Panel Set Complete	8613035	
13036	Flexbar Panel Guard™ 2-Panel Expansion Set	8613036	
13037	Flexbar Panel Guard™ Extra Slide-In Flexible Hinge (1 ea.)	8613037	