

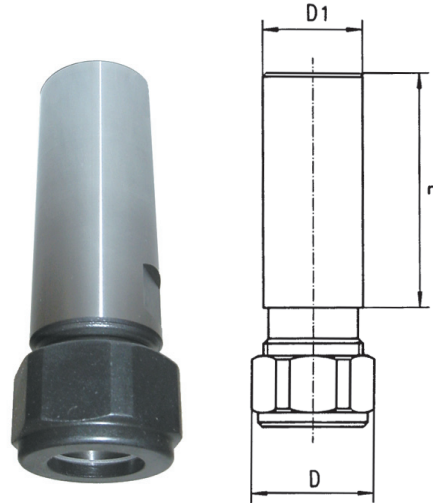

**DA-180 COLLETS,
COLLET CHUCKS AND KITS**

SERIES 992:

- Full 1/32" range of collapse.
- Concentricity within 0.0005" T.I.R. at collet nose assembled with chuck.
- Self release for rapid, easy operation.
- Interchangeable with all DA-180 Collets and Collet Chucks.
- DA Collets Concentricity guaranteed to 0.0004".



Shank Dia. D	Collet Range	L	Order No.	Price
1-1/4"	1/4"-3/4"	3 5-1/2	7167023 7167025	

Taper NMTB	Collet Range	L	Order No.	Price
30	1/4"-3/4"	3	7167013	
40		3	7167014	
50		3-1/2	7167015	

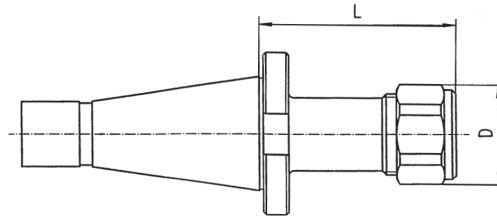

Description	Order No.	Price
Nut	7193818	
Wrench	7193918	

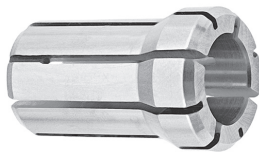

COLLET DIMENSIONS

Collet Series	Collet Range	Body Dia.	Overall Length
DA-180	1/4"-3/4"	0.873-1.035	1.637

SPRING COLLETS - METRIC

Nominal Size	Collet Range	Order No.	Price
3	3-2	7167503	
4	4-3	7167504	
5	5-4	7167505	
6	6-5	7167506	
7	7-6	7167507	
8	8-7	7167508	
9	9-8	7167509	
10	10-9	7167510	
11	11-10	7167511	
12	12-11	7167512	
13	13-12	7167513	
14	14-13	7167514	
15	15-14	7167515	
16	16-15	7167516	
17	17-16	7167517	
18	18-17	7167518	
19	19-18	7167519	

SPRING COLLETS - FRACTIONAL

1761

Nominal Size	DA-180 Code No.	Price	Nominal Size	DA-180 Code No.	Price	
1/8	7167110		15/32	7167132		
9/64	7167111		31/64	7167133		
5/32	7167112		1/2	7167134		
			33/64	7167135		
11/64	7167113		17/32	7167136		
3/16	7167114		35/64	7167137		
13/64	7167115		9/16	7167138		
7/32	7167116		37/64	7167139		
15/64	7167117		19/32	7167140		
1/4	7167118		39/64	7167141		
17/64	7167119		5/8	7167142		
9/32	7167120		41/64	7167143		
19/64	7167121		21/32	7167144		
5/16	7167122		43/64	7167145		
21/64	7167123		11/16	7167146		
11/32	7167124		45/64	7167147		
23/64	7167125		23/32	7167148		
3/8	7167126		47/64	7167149		
25/64	7167127		3/4	7167150		
13/32	7167128		17pc. Set	7167192		
27/64	7167129		1/4"-3/4"			
7/16	7167130		x 1/32nd			
29/64	7167131					
			33pc. Set	7167194		
			1/4"-3/4"			
			x 1/64ths			

DA 100, DA 200, DA300
COLLETS & EXTENSIONS available.
See our website or inquire.

**MILLING CHUCK
AND COLLET SETS**

SERIES 663:



- Best selected quality tool steel hardened and precision ground.
- Accuracy concentric to within .008" per inch.
- High rigidity and clamping force.

7pc. collet set includes:
(1/4, 5/16, 3/8, 1/2, 5/8, 3/4, 1")

15pc. collet set includes:
(7 pc. set plus 1/8, 3/16, 7/16, 9/16, 11/16, 13/16, 7/8, 15/16")

Each set includes: 1 chuck shank holder, 1 wrench, 1 plastic case, 7 or 15 collets

Taper	No. of Collets	Draw Bar Thread	Order No.	Price
R-8	7	7/16-20	6000050	
R-8	15	7/16-20	6000051	
NT40	7	5/8-11	6000052	
NT40	15	5/8-11	6000053	



ER-16 MINI SPRING COLLET CHUCK SYSTEM



FINEST QUALITY / ULTRA PRECISE

SERIES 663:

- **WIDE HOLDING RANGE OF EACH COLLET:** The ER-16 Collets have a range of .040" (1.00mm) per Collet. Guarantees that undersize and oversize cutting tools can be held without sacrificing accuracy or gripping power.
- **REDUCES THE NUMBER OF COLLETS REQUIRED** to cover the range from .020"(0.5mm) - .393"(10.0mm). Only 10 collets required with ER-16. (Other systems require 23-27 collets.)
- **UNIVERSAL COLLET TYPE:** The 8° taper design with double angle makes the ER-16 Universal Collet suitable for both milling and drilling operations.
- **SIXTEEN MILLED SLOTS:** provide 16 Jaws - for higher concentricity and high gripping power, allowing cutting tools to be held on flutes.
- **SHORT COLLET DESIGN:** ER-16 Short Collet design for less over-hang to prevent small cutting tool breakages.
- **SMALL NOSE DIA.:** Minimum nose dia. of the ER-16 Collet Chuck is useful for hard-to-reach milling and drilling operations.
- **A UNIQUE SELF-RELEASING SYSTEM** is built into the collet and nose piece to eliminate cutting tools from sticking in the collet.

MILLING & DRILLING EXTENSION SETS

Including Chuck and Set of ER Spring Collets and Wrench in fitted case.



SPRING COLLETS (INDIVIDUAL)

Range		Order No.	Price
Inch	mm		
(.02-.04) 1/32	0.5-1.0	6641601	
(.040-.080) 1/16	1.0-2.0	6641612	
(.080-.120) 3/32	2.0-3.0	6641623	
(.120-.160) 1/8	3.0-4.0	6641634	
(.160-.200) 3/16	4.0-5.0	6641645	
(.200-.236) 7/32	5.0-6.0	6641656	
(.236-.275) 1/4	6.0-7.0	6641667	
(.275-.315) 5/16	7.0-8.0	6641678	
(.315-.354) 11/32	8.0-9.0	6641689	
(.354-.393) 3/8	9.0-10.0	6641690	



Shank	Collet Type	Full Set Pcs.	Collapse Capacity	Set Range	Order No.	Price
R8	ER16	10	.04	1/32-3/8" .02-.393	6640001	
3/4 x 2-1/2					6640002	
3/4 x 4					6640003	
3/4 x 6					6640004	

SPRING COLLET SET

No. Pcs. Per Set	Collet Range		Set Range		Order No.	Price
	Inch	mm	Inch	mm		
10	.040	1	.020-.393	0.5-10	6641699	

**R8 AND STRAIGHT SHANK
EXTENSION COLLET CHUCKS**

Shank	L	Order No.	Price
R8	-	6640005	
3/4	2-1/2	6640006	
3/4	4	6640007	
3/4	6	6640008	



STRAIGHT SHANK

WRENCH FOR ER-16 SYSTEM

Order No.	Price
6640200	





ER-40 COLLET CHUCK SYSTEM

FINEST QUALITY / ULTRA PRECISE

SERIES 663:

- WIDE HOLDING RANGE of each collet (ER-40 collets have a range of .040") guarantees that undersize and oversize cutting tools can be held without sacrificing accuracy or gripping power; permits number and metric sizes to be used; **reduces the number of collets to cover a given range.**
(Just 23 ER-40 collets are needed to cover a range of : .118"-1"; some systems require 57 collets for the same range.)
- UNIQUE 8° TAPER DESIGN - affords highest gripping power; allows for the thickest segments to prevent twisting of the collets under heavy loads; gives least overhang.
- TRUE DOUBLE ANGLE; the collet features a wide closing taper in relation to the 8° clamping taper- for extreme concentricity; for powerful gripping; and for parallel clamping.
- SIXTEEN MILLED SLOTS provide 16 jaws - giving higher concentricity and clamping power; allowing cutting tool to be held on flutes.
- A UNIQUE, SELF RELEASING SYSTEM is built into the collet and nose piece — eliminates cutting tools sticking in collets.

How This Collet Chuck System SAVES —

It saves you time and effort... simplifies tool changing on conventional milling machines and eliminates awkward use of draw bar. The safety wrench has four gripping points. In addition, you can use the same chuck for milling, drilling (holding on flutes), reaming, tapping, boring, etc. There's more, too: All ER collet chucks are internally threaded for an internal stop so that cutting tools can be changed to a predetermined length. All NT 40 chucks fit Erickson flange tooling systems. Finally, all ER collet chucks with NT 40 taper have a plastic ring on the taper end of the chuck to protect machine spindles.

MASTER TOOLING SETS

Including chuck and set of spring collets and wrench in fitted case.



Collet Sizes in Sets	Shank	Order No.	Price
15 Collets: 1/8, 3/16, 1/4, 5/16, 3/8, 7/16, 1/2, 9/16, 5/8, 11/16, 3/4, 13/16, 7/8, 15/16, 1	R8	6630001	
	30	6630002	
	40	6630003	
	50	6630004	
	3 MT	6630005	
	4 MT	6630006	
	5 MT	6630007	
	Straight - 1 x 2-3/8	6630008	
	Straight - 1-1/4 x 2-3/8	6630009	



SPRING COLLETS

Collet Range (Inch)	Collet Range (mm)	Order No.	Price
1/8 - .12 - .16	3-4	6631773	
3/16 - .16 - .20	4-5	6631774	
7/32 - .20 - .236	5-6	6631775	
1/4 - .236 - .275	6-7	6631776	
5/16 - .275 - .315	7-8	6631777	
11/32 - .315 - .354	8-9	6631778	
3/8 - .354 - .393	9-10	6631779	
13/32 - .393 - .433	10-11	6631780	
7/16 - .433 - .472	11-12	6631781	
1/2 - .472 - .511	12-13	6631782	
17/32 - .511 - .551	13-14	6631783	
9/16 - .551 - .590	14-15	6631784	
5/8 - .590 - .629	15-16	6631785	
21/32 - .629 - .669	16-17	6631786	
11/16 - .669 - .708	17-18	6631787	
3/4 - .708 - .750	18-19	6631788	
25/32 - .750 - .787	19-20	6631789	
13/16 - .787 - .826	20-21	6631790	
27/32 - .826 - .866	21-22	6631791	
7/8 - .866 - .905	22-23	6631792	
15/16 - .905 - .944	23-24	6631793	
31/32 - .944 - .984	24-25	6631794	
1 - .984 - 1.02	25-26	6631795	

COLLET CHUCKS

Shank	Order No.	Price
R8	6630010	
30	6630011	
40	6630012	
50	6630013	
3MT	6630014	
4MT	6630015	
5MT	6630016	
Straight- 1 x 2 3/8	6630017	
Straight - 1 1/4 x 2 3/8	6630018	



SPRING COLLET SET

No. Pcs. Per Set	Collet Range	Set Range	Order No.	Price
23	.040"	.118" - 1"	6631770	

WRENCH FOR ER-40 SYSTEM

Order No.	Price
6631972	



INDIVIDUAL ER SPRING COLLETS AND COLLET KITS - INCH

SERIES 664:

ER COLLETS CONCENTRICITY
GUARANTEED TO 0.0004"

- Due to the wide holding range of each collet, fewer collets and changes are required.
- Unique self-releasing system eliminates sticking.
- ER Mini-Collet Chucks allow for machining in tight locations with reduced outside nose diameter.



Nominal Size	Collet Range	ER-11		ER-16		ER-20		ER-25		ER-32		ER-40	
		Order No.	Price	Order No.	Price	Order No.	Price	Order No.	Price	Order No.	Price	Order No.	Price
1/32	.020-.040	7171112		7171162		-		-		-		-	
1/16	.040-.080	7171113		1711621		7171203		1712333		-		-	
3/32	.080-.120	7171114		1711623		7171204		1712335		7171328		-	
1/8	.120-.160	7171116		7171163*		7171205*		1712337*		7171330*		7171430*	
5/32	.150-.190	-		1711630		-		-		-		-	
3/16	.160-.200	7171118		7171164*		7171207*		7171234*		7171334*		7171434*	
7/32	.200-.236	7171120		7171165*		7171209*		7171236*		7171336		7171436	
1/4	.236-.275	7171122		7171166*		7171211*		7171238*		7171338*		7171438*	
9/32, 5/16	.275-.315	-		7171167*		7171213*		7171242*		7171340*		7171442*	
11/32	.315-.354	-		7171168*		7171215*		7171244*		7171344		7171444	
3/8	.354-.393			7171169*		7171217*		7171246*		7171346*		7171446*	
13/32	.393-.433			-		7171219*		7171248*		7171348		7171448	
7/16, 15/32	.433-.472			-		7171221*		7171250		7171350*		7171450*	
1/2	.472-.511			-		7171223*		7171254*		7171354*		7171454*	
17/32	.511-.551			-		-		7171256*		7171356		7171456	
9/16	.551-.590			-		-		7171258*		7171358*		7171458*	
19/32, 5/8	.590-.629			-		-		-		7171362*		7171462*	
21/32	.629-.669			-		-		-		7171364		7171464	
11/16	.669-.708			-		-		-		7171366*		7171466*	
23/32, 3/4	.708-.748			-		-		-		7171370*		7171470*	
25/32	.748-.787			-		-		-		-		7171472	
13/16	.787-.826			-		-		-		-		7171474*	
27/32	.826-.866			-		-		-		-		7171476	
7/8	.866-.905			-		-		-		-		7171478*	
29/32, 15/16	.905-.944			-		-		-		-		7171482*	
31/32	.944-.984			-		-		-		-		7171484	
1	.984-1.02			-		-		-		-		7171486*	
Collet Sets: Order No.		7 Piece Set 7171125		7 Piece Set 7171195		10 Piece Set 7171225		12 Piece Set 7171295		11 Piece Set 7171395		15 Piece Set 7171495	
Price													

*Included in set

ER COLLET CHUCKS AND KITS

SERIES 664:



Collet Size	Shank Size	Overall Lgth	Collet Chuck Order No.	Price	Kit Order No.	Price	Collet Size	Shank Size	Overall Lgth	Collet Chuck Order No.	Price	Kit Order No.	Price
ER-11	1/2	6.2	1711105		1711115		ER-32	R8	6-1/4	1713008		1713108	
	5/8		1711106		1711116			NMTB 30	5-1/16	1713030		1713130	
ER-16	5/8	6.0	1711606		1711616		NMTB 40	6-1/16	1713040		1713140		
	3/4		6.5	1711607		1711617		MT-3	6-1/16	1713003		1713103	
ER-20	3/4	5.5	1712007		1712017		1	3-3/4	1713001		1713101		
	1		1712009		1712019		ER-40	R8	6-1/2	1714008		1714108	
ER-25	3/4	6.5	1712303		1712313			NMTB 40	6-1/16	171404		1714140	
	1		1712305		1712315			NMTB 50	7-3/4	1714050		1714150	
						1		4-1/2	1714001		1714101		
							1-1/4	4-3/4	1714002		1714102		

ER COLLET WRENCHES AND NUTS

SERIES 664:

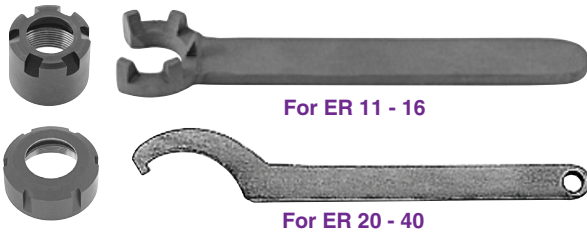

**Quality Machine
Tool Accessories**



The Choice Is Yours!!!

Collet Type	Nut		Wrench	
	Order No.	Price	Order No.	Price
ER-11	7171951		7171961	
ER-16	7171966		7171976	
ER-20	7188820		7188916	
ER-25	7188825		7188925	
ER-32	7188832		7188932	
ER-40	7188840		9180930	



While we show the most popular **BISON** items, we can supply their entire range of products; please inquire.



INDIVIDUAL ER SPRING COLLETS, AND COLLET KITS - METRIC

SERIES 664:



ER COLLET SETS



Nominal Size	Collet Range mm	Collet Range inch	ER-11 Order No.	Price	ER-16 Order No.	Price	ER-20 Order No.	Price	ER-25 Order No.	Price	ER-32 Order No.	Price	ER-40 Order No.	Price
1	1-0.5	.019-.039	7171511		7171501		-		-		-		-	
2	2-1	.039-.078	7171513		7171502		7171602		-		-		-	
3	3-2	.078-.118	7171515		7171503		7171603		7171703		7171803		-	
4	4-3	.118-.157	7171517		7171504		7171604		7171704		7171804		7171904	
5	5-4	.157-.196	7171519		7171505		7171605		7171705		7171805		7171905	
6	6-5	.196-.236	7171521		7171506		7171606		7171706		7171806		7171906	
7	7-6	.236-.275	7171523		7171507		7171607		7171707		7171807		7171907	
8	8-7	.275-.314	-		7171508		7171608		7171708		7171808		7171908	
9	9-8	.314-.354	-		7171509		7171609		7171709		7171809		7171909	
10	10-9	.354-.393	-		7171510		7171610		7171710		7171810		7171910	
11	11-10	.393-.433	-		-		-		7171711		7171811		7171911	
12	12-11	.433-.472	-		-		7171612		7171712		7171812		7171912	
13	13-12	.472-.511	-		-		7171613		7171713		7171813		7171913	
14	14-13	.511-.551	-		-		-		7171714		7171814		7171914	
15	15-14	.551-.590	-		-		-		7171715		7171815		7171915	
16	16-15	.590-.629	-		-		-		7171716		7171816		7171916	
17	17-16	.629-.669	-		-		-		-		7171817		7171917	
18	18-17	.669-.708	-		-		-		-		7171818		7171918	
19	19-18	.708-.748	-		-		-		-		7171819		7171919	
20	20-19	.748-.787	-		-		-		-		7171820		7171920	
21	21-20	.787-.826	-		-		-		-		-		7171921	
22	22-21	.826-.866	-		-		-		-		-		7171922	
23	23-22	.866-.905	-		-		-		-		-		7171923	
24	24-23	.905-.944	-		-		-		-		-		7171924	
25	25-24	.944-.984	-		-		-		-		-		7171925	
26	26-25	.984-1.023	-		-		-		-		-		7171926	
Collet Sets:			7 Pc. Set		10 Pc. Set		11 Pc. Set		14 Pc. Set		18 Pc. Set		23 Pc. Set	
Order No.			7171525		7171595		7171695		7171795		7171895		7171935	
Price														